

3 601 JF4 080

Issue } 15-02-02 Fig./Abb. 1  
Stand }

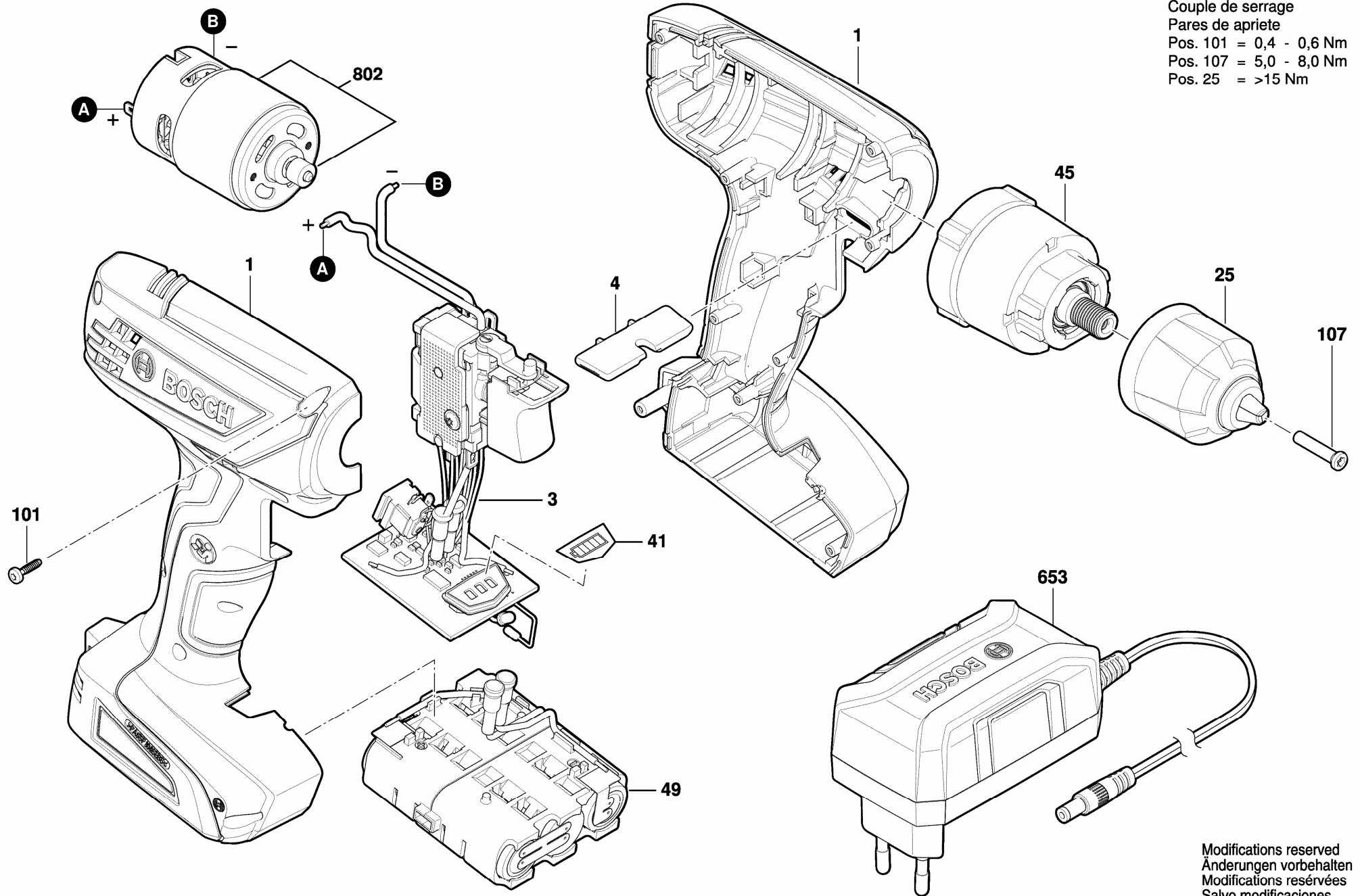

Anzugsmomente  
Torque values  
Couple de serrage  
Pares de apriete  
Pos. 101 = 0,4 - 0,6 Nm  
Pos. 107 = 5,0 - 8,0 Nm  
Pos. 25 = >15 Nm

Modifications reserved  
Änderungen vorbehalten  
Modifications réservées  
Salvo modificaciones